

Internal Use Only:				
	Date Received	Reviewed By/Date	Preliminary Appv'l Date	Final Appv'l Date

PARK COUNTY ROAD WORK PERMIT APPLICATION

Location of Work:

Rural Address/Description: _____

Name: _____ E-mail: _____

Mailing Address: _____

Phone: _____ Cell Phone: _____ Fax: _____

Owner/Applicant Information:

Name: _____ E-mail: _____

Business Name: _____

Mailing Address: _____

Phone: _____ Cell Phone: _____ Fax: _____

Person/Company performing the work:

Company Name: _____ Project Manager: _____

Contact Phone Number: _____ E-mail: _____

Mailing Address: _____

Work to be Performed Start Date: _____ Completion Date: _____		Required Fees and Documentation						
		Fee	Road Work Permit**	Certificate of Insurance	Enviro. Checklist. & Permits	Drainage Report	Traffic Impact Analysis	Certified Plans & Specs.
Approach	<input type="checkbox"/>	\$250	✓	✓				
Cattle Guard	<input type="checkbox"/>	\$250	✓	✓				
Minor Encroachment	<input type="checkbox"/>	\$250	✓	✓				
Major Encroachment	<input type="checkbox"/>	1% of Cost*	✓	✓	✓	✓	✓	✓
Magnesium Chloride	<input type="checkbox"/>	Waived	✓	✓				
Snow Plowing	<input type="checkbox"/>	Waived	✓	✓				
Subdivision	<input type="checkbox"/>	1% of Cost*	✓	✓	✓	✓	✓	✓
Other	<input type="checkbox"/>	Public Utilities or Other: Contact Park County for Fee and Documentation						
Included:	\$	<input type="checkbox"/>	<input type="checkbox"/>	<input type="checkbox"/>	<input type="checkbox"/>	<input type="checkbox"/>	<input type="checkbox"/>	<input type="checkbox"/>

*Cost defined as estimate of material plus installed (as-constructed) present value of work within Right of Way, \$250 minimum fee
 ** Attach a description of proposed work with a sketch of plan: (Must include Scale, North Arrow, legal description and plan or cross-section view)

_____ **PROPERTY OWNER/APPLICANT SIGNATURE** _____ **SUBMISSION DATE**
FEES PAYABLE TO PARK COUNTY, 414 E. CALLENDER ST, LIVINGSTON, MT 59047

Subject to the following terms and conditions, the permit applied for is hereby granted:

Pursuant to Title 7, Chapter 14, MCA, inter alia, any person or agency performing any work in a County Road right of way must first obtain a permit from the Public Works Department. Permits are issued for driveways, road approaches, underground and aerial utility work, and any other kind of work performed or structure placed within the road right of way. Refer to Park County Transportation Standards for additional encroachment items. Any work on a Park County road or a new subdivision road requires a Permit Application through the Park County Public Works Road Department.

Applicant will complete this form along with plans, sketches along with required documentation and send to Park County for review and approval. Refer to Park County Transportation Standards for requirements specific to additional documentation.

Minor encroachments are considered as having a material plus installed (as-constructed) present value of \$25,000 or less within the right of way. Major encroachments are considered as having a material plus installed (as-constructed) present value of over \$25,000 within the right of way.

No work may be performed until Park County has given written preliminary approval for the project. The work and associated operations shall be conducted so that there is minimal interruption in the use and associated impacts to affected roads. Exact procedures in this respect shall be established in advance of mobilization. All work shall conform to Park County Transportation Standards and other applicable local, state and federal regulations.

The application is not a permit until the approval is completed by Park County. Upon approval by Park County "County", the "Applicant" becomes the "Permittee" and agrees to the terms of this permit.

COUNTY SAVED HARMLESS FROM CLAIMS. As a consideration of being issued this permit, the Permittee, its successors or assigns, agrees to protect the COUNTY and save it harmless from all claims, actions or damage of every kind and description which may accrue to, or be suffered by, any person or persons, corporations or property by reason of the performance of any such work, character of materials used, or manner of installations, maintenance and operation, or by the improper occupancy of said roadway right-of-way, and in case any suit or action is brought against the County and arising out of, or by reason of, any of the above causes, the Permittee, its successors or assigns, will, upon notice to them of the commencement of such action, defend the same at its sole cost and expense and satisfy any judgment which may be rendered against the County in any such suit or action. Contractor's performing work in the public right of way shall be licensed, bonded, and insured holding the County harmless in the amount of \$1,000,000. the Applicant is required to provide a Certificate of Insurance naming Park County as additional insured prior to permit approval. Final Inspection approval is required prior to removing the County from additional insured.

TERM. This permit shall be in full force and effect from the date hereof until revoked as herein provided. Permits are issued for a ninety (90) day period. All construction work must be complete within the 90 period unless otherwise stated on the Permit. An extension may be granted by Park County for up to an additional 90 days. If no extension is granted the applicant must resubmit the application and fee.

REVOCATION. This permit may be revoked by the County upon giving **45** days notice to Permittee by ordinary mail, sent to the address shown herein. However, the County may revoke this permit without notice if Permittee violates any of its conditions or terms.

COMMENCEMENT OF WORK. No work shall be commenced until Permittee notifies the County shown in application the date the Permittee proposes to commence work.

CHANGES IN ROADWAY. If County roadway changes necessitate changes in structures or installations installed under this permit, Permittee will make necessary changes without expense to the County.

PROTECTION OF TRAFFIC. The Permittee shall protect the work area with traffic control devices that comply with the Manual of Uniform Traffic Control Devices. The Permittee may be required to submit a traffic control plan to the County for approval prior to starting work. During work, the County or designee may require the Permittee to use additional traffic control devices to protect traffic or the work area. No road closure shall occur without prior approval from the County Board of Commissioners.

ROADWAY AND DRAINAGE. If the work done under this permit interferes in any way with the drainage of the County roadway affected. Permittee shall, at the Permittee's expense, make such provisions as the County may direct to remedy the interference.

RUBBISH AND DEBRIS. Upon completion of work contemplated under this permit, all rubbish and debris shall be immediately removed and the roadway and roadside left in a neat and presentable condition satisfactory to the County.

INSPECTION. The installation authorized by this permit shall be in compliance with the attached plan and the conditions of this permit. The Permittee may be required to remove or revise the installation, at sole expense of Permittee. If the installation does not conform with the requirements of this permit or the attached plan.

COUNTY'S RIGHT NOT TO BE INTERFERED WITH. All changes, reconstruction or relocation shall be done by Permittee so as to cause the least interference with any of the County's work, and the County shall not be liable for any damage to the Permittee by reason of any such work by the County, its agents, contractors or representatives, or by the exercise of any rights by the County upon the roadways by the installations or structures placed under this permit.

REMOVAL OF INSTALLATIONS OR STRUCTURES. Unless waived by the County, upon termination of this permit, the Permittee shall remove the installations or structures installed under this permit at no cost to the County and restore the premises to the prior existing condition, reasonable and ordinary wear and tear and damage by the elements, or by circumstances over which the Permittee has no control, excepted.

MAINTENANCE AT EXPENSE OF PERMITTEE. Permittee shall maintain, at its sole expense, the installations and structures for which this permit is granted, in a condition satisfactory to the County.

COUNTY NOT LIABLE FOR DAMAGE TO INSTALLATIONS. In accepting this permit, the Permittee agrees that any damage or injury done to said installations or structures by a contractor working for the County, or by any County employee engaged in construction, alteration, repair, maintenance or improvement of the County roadway, shall be at the sole expense of the Permittee.

COUNTY TO BE REIMBURSED FOR REPAIRING ROADWAY. Upon being billed, therefore, Permittee agrees to promptly reimburse County for any expense incurred in repairing surface of roadway due to settlement at installation, or for any other damage to roadway as a result of the work performed under this permit.

The Permittee shall not discharge or cause discharge of any hazardous or solid waste by the installation or operation of the facility of a county Right-of-Way.

The Permittee will control noxious weeds within the disturbed installation area for two (2) years.

In accordance with Mont. Code Ann. § 76-3-403(2), Permittee shall, at Permittee's expense, employ the services of a Montana Licensed Professional Land Surveyor to re-establish all existing survey monuments disturbed by work contemplated under this permit.

The use of explosives is prohibited for the installation.

Any condition of this permit shall not be waived without written approval of the County.

OTHER CONDITIONS AND/OR REMARKS: _____

PRELIMINARY APPROVAL:

Preliminary Review:

By _____ Date _____

Preliminary Approval:

Granted _____ Denied _____

Park County Public Works Department:

Representative

Signature _____ Date _____

Required for Major Encroachments / Subdivisions:

Public Works Director:

Signature _____ Date _____

Park County Commissioners:

Signature _____ Date _____

Signature _____ Date _____

Signature _____ Date _____

FINAL APPROVAL:

Final Review:

By _____ Date _____

Final Approval:

Granted _____ Denied _____

Park County Public Works Department:

Representative

Signature _____ Date _____

Required for Major Encroachments / Subdivisions:

Public Works Director:

Signature _____ Date _____

Park County Commissioners:

Signature _____ Date _____

Signature _____ Date _____

Signature _____ Date _____

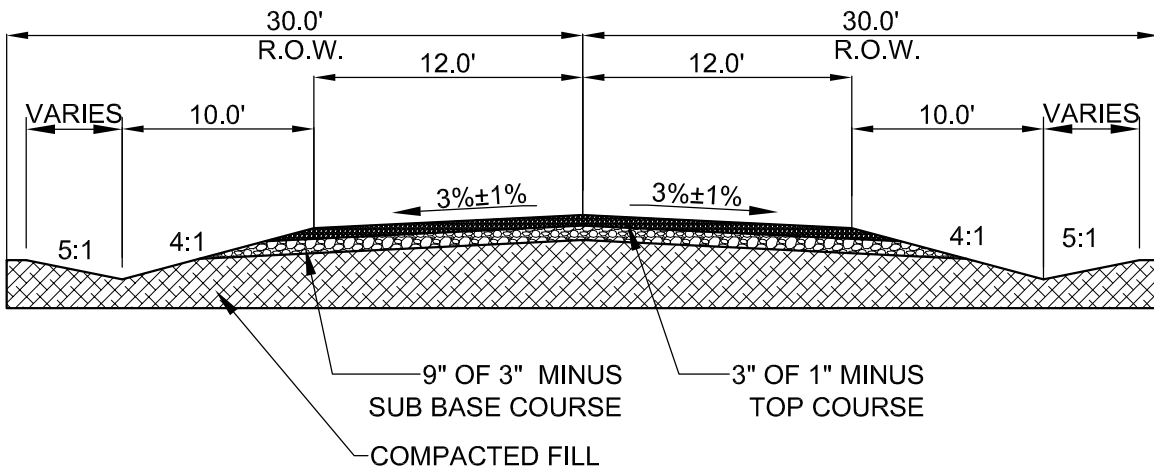

TYPICAL GRAVEL ROAD SECTION

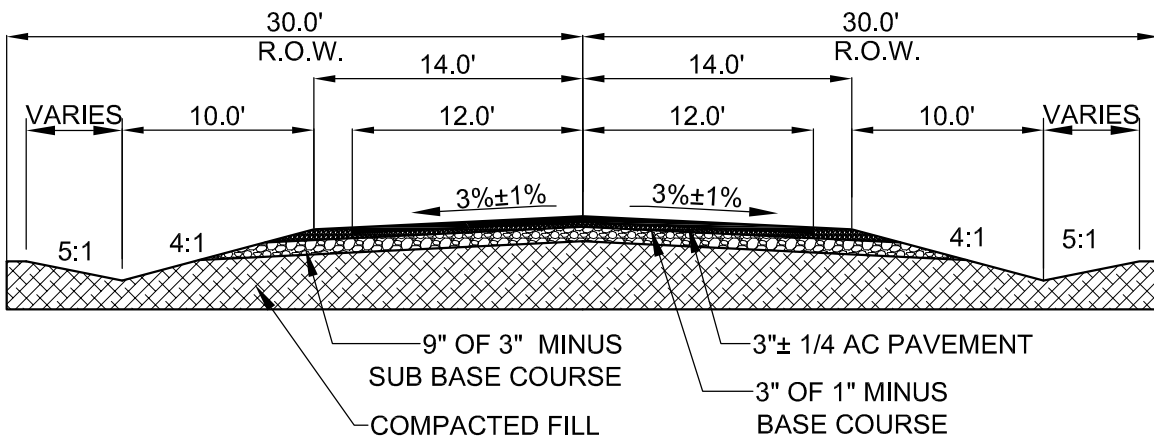

TYPICAL ASPHALT ROAD SECTION

Drawn By _____ CJM
 Checked By _____ KJF
 Date _____ 07/24/14
 CTA # _____ PRKCTY
 Cad File: _____ N/A



PARK COUNTY, MT
 TYPICAL ROAD CROSS-SECTIONS

ADDENDUM

REF SHEET#

SHEET#

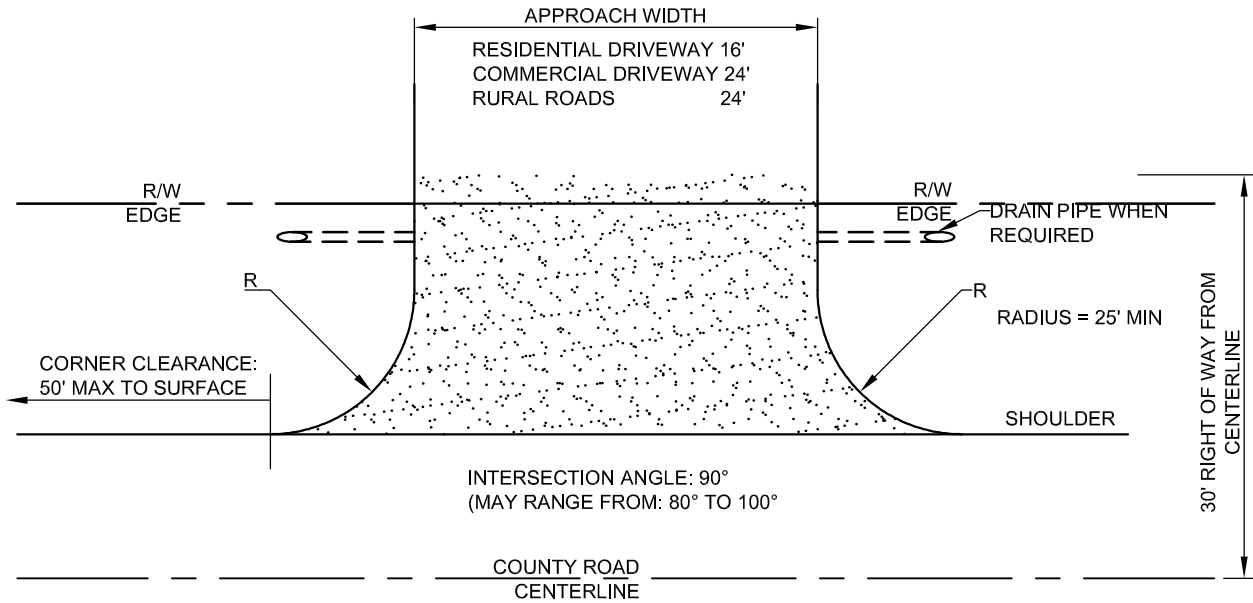

SHOULDER
EXHIBIT "A" ROAD APPROACH PLAN VIEW AND DIMENSIONS

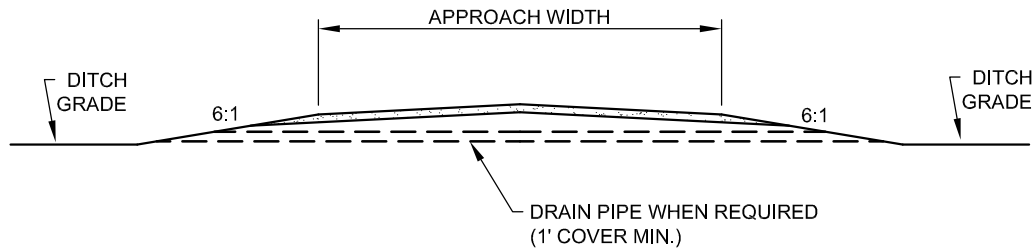

EXHIBIT "B" SIDE SLOPE

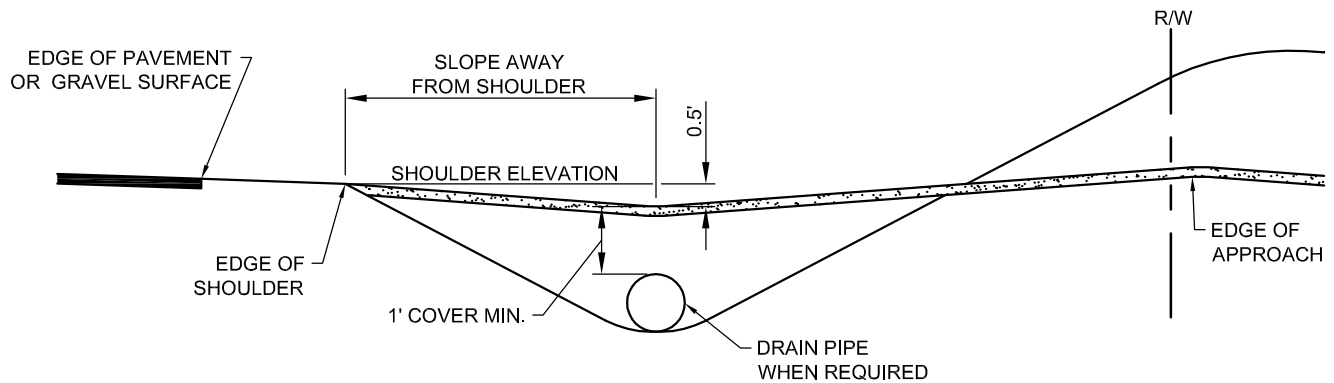

EXHIBIT "C" GRADING AND DRAINAGE

Drawn By CJM
 Checked By KJF
 Date 07/24/14
 CTA # PRKCTY
 Cad File: N/A

CTA
 BILLINGS, MT
 (406)248-7455
 Fax (406)248-3779

PARK COUNTY, MT
 TYPICAL ROAD APPROACH

ADDENDUM

REF SHEET#

SHEET#